

WEB JOIST

Inspired by Integrity

WARNING*WARNING*WARNING

Web-i Joists are unstable until adequately braced. Inadequate bracing could result in serious injury and harm.

1. The purchaser is responsible for unloading the WEB-i joists off the truck. Proper equipment should be used and care taken to avoid damage to the product.
2. WEB-i joists are normally delivered in bundles of twenty-three (23); bundles should remain intact until ready for installation to avoid damage.
3. If storage is required at the jobsite, place bundles on level stickers to avoid prolonged contact with mud and water. Cover as you would other building products.
4. WEB-i joists should ALWAYS be handled and installed in an upright vertical position.
5. Cutting, drilling, or any other altering of wood flanges is not allowed unless approved by Web Joist Northwest Corp. For holes in web, see attached table and instructions. Cutting joist to length to fit building is permitted.
6. Customer assumes all responsibility for installation, temporary bracing, and all other handling of joists at time of delivery.
7. Please call your sales representative if you have any questions or require further information on your WEB-i joists.

See Attached Pages

WEB-i[®] INSTALLATION INFORMATION

ATTACHMENT OF SPRINKLER SYSTEMS TO WEB-i JOISTS

1. Before installation of sprinkler system hardware contact Web Joist for approval of diameter and spacing of coach rods and other hardware.
2. Manufacturer must approve of method and maximum weight suspended from Web-i Joists in writing prior to installation.
3. Submit details or sketches of desired method of attachment for engineering consideration. Provide maximum loads for each method of attachment.
4. $\frac{3}{8}$ " coach screw rods must be installed within $\frac{3}{8}$ " of centerline of Web-i bottom flanges. Always pre-drill with $\frac{1}{4}$ " pilot hole.

DO NOT EXCEED THE MANUFACTURERS STRUCTURAL CAPACITY. CONTACT WEB JOIST BEFORE INSTALLATION.

CAUTION

Install all Web-i Joists shown on shop drawings, including extra joists shown at special loading conditions (if required), and openings that exceed normal spacing, (by more than 15%) head-outs require a multiple joist on each side. See shop drawings for details at openings and at headers.

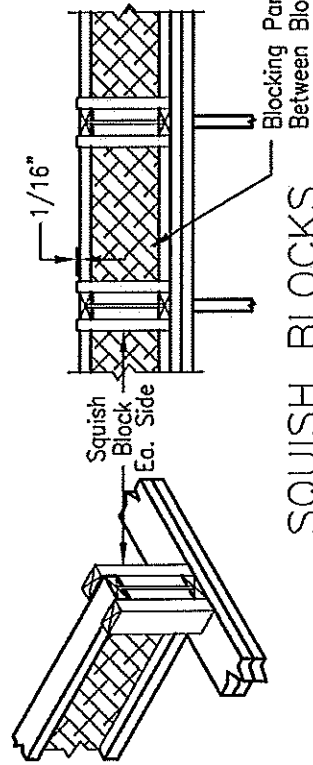

SQUISH BLOCKS

WARNING - READ ALL INFORMATION

Do not allow workers onto Web-i Joists until all hangers, web stiffeners, blocking panels, and temporary bracing are fully installed in accordance with Web Joist guidelines. Inadequate attention to proper bracing and support of Web-i Joists can result in serious worker injury.

1. WEB-i Joists must be braced laterally for strength and tied to walls at both ends of each bay of Web-i Joists. This can be accomplished with temporary / permanent horizontal bracing of top flanges of Web-i Joists. Without this lateral bracing a sideways buckling (or roll-over) is possible under very light construction loads.
2. WEB-i Joists are unstable. All web stiffener blocks, hangers, blocking panels, and sheathing must be properly installed and attached before any other loads are to be imposed on the Web-i Joists. Maximum allowable out of tolerance from verticle = $\frac{1}{2}$ ".

GENERAL NOTES

1. Double and triple joists are for field assembly unless otherwise noted in material list (above right).
2. Nail as shown or stitch bolt w/ $\frac{3}{8}$ " Dia. M. bolt of sufficient length at 48" o.c. or as indicated in details herein. Assemble and install all doubles as shown.
3. Nails to be equally spaced (min 3") with less than 2" between last nail & top or bottom of web stiffener block. Offset rows of nails as necessary.
4. Web stiffener blocks may be required at specific locations due to concentrated loads imposed on joists.

Nail multiple joists with 5-16d per blk.

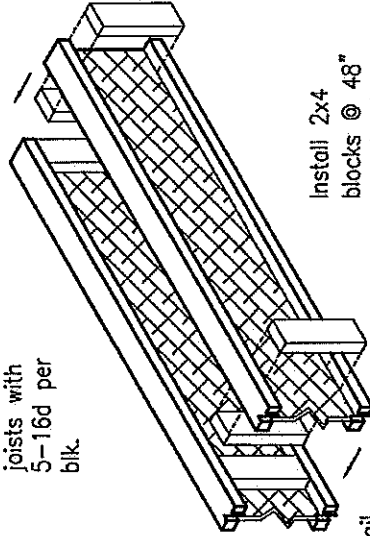

Install 2x4 blocks @ 48" o.c. (typ.)

Additional web stiffeners required for triple joists, same nailing as above.

WEB STIFFENER NAILING TABLE

(Total Nails - 1/2 Applied from Each Side)

Joist Depth	Simple Span		Continuous Span	
	3/8" Web (Box)	1/2" Web (Corn)	3/8" Web (Box)	1/2" Web (Corn)
12"	3-10d	---	4-10d	---
14"	4-10d	---	6-10d	---
16"	4-10d	4-10d	6-10d	6-10d
18"	5-10d	5-10d	7-10d	7-10d
20"	6-10d	6-10d	9-10d	9-10d
22"	6-10d	6-10d	9-10d	9-10d
24"	7-10d	7-10d	10-10d	10-10d
26"	---	8-10d	---	12-10d
28"	---	8-10d	---	12-10d

Web stiffeners are No. 2 or better. Use 2x4's at simple spans and 2x6's at continuous spans. Install nails from both sides.

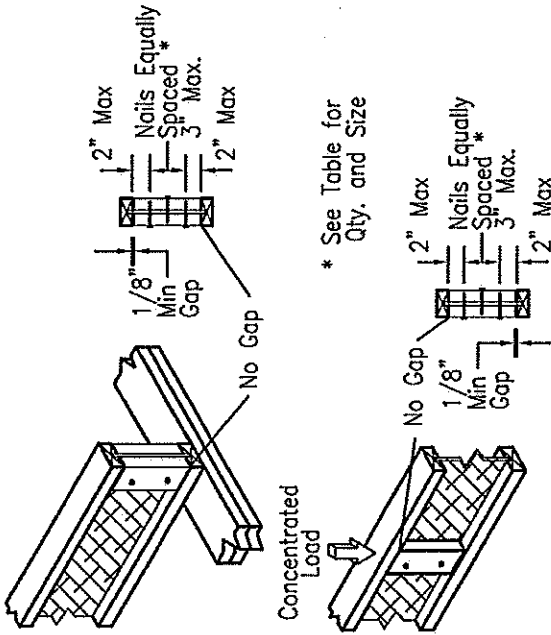

* See Table for Qty. and Size

WEB STIFFENERS

Recommended minimum on center spacing for nails and staples in a single row.^{1, 3}

Nail Size	Staple Size ²	Minimum (O.C. Spg.)
8d Box	15 Ga.	3.75"
8d Corn	13 Ga.	4.50"
10d Box	14 Ga.	4.25"
10d Corn	12 Ga.	5.00"
12d Box	14 Ga.	4.25"
12d Corn	12 Ga.	5.00"
16d Box	13 Ga.	4.50"
16d Corn	12 Ga.	5.50"

- For tighter on center spacing, consider predrilling holes no greater than 0.75 x nail diameter to prevent splitting. (per 1997 NDS SEC 12.1.3.1)
- 1/16" min. o.d. crown width and 1/16" min. penetration into chord member.
- If more than (1) one row offset rows at least 1/2".

RECOMMENDED NAIL SPACING

SUPPORT FOR CONG. LOADS

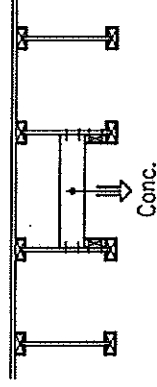

LATERAL SUPPORT FOR DRAG

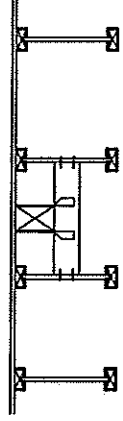

SUPPORT FOR MECH. LOADS

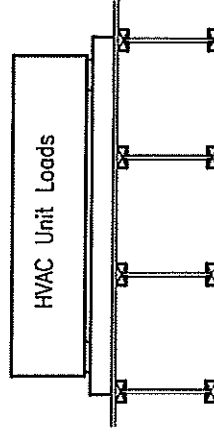

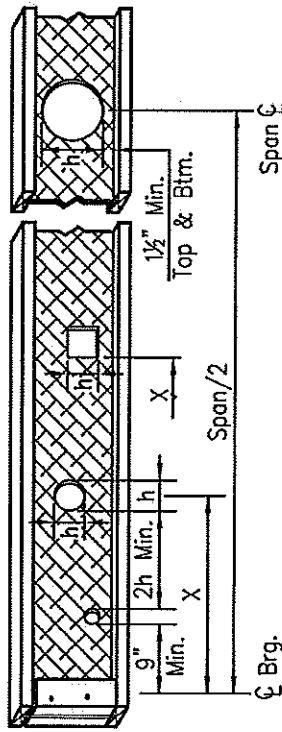

WEB HOLE SIZE AND LOCATION

Joist Depth (in.)	Hole Factor (F)												
	Effective Height (EH)												
12	0.1463	0.1951	0.2439	0.2927	0.3415	0.3903	0.4391	0.4879	0.5367	0.5855	0.6343	0.6831	0.7319
14	0.1224	0.1633	0.2041	0.2449	0.2857	0.3265	0.3673	0.4081	0.4489	0.4897	0.5305	0.5713	0.6121
16	0.1053	0.1404	0.1754	0.2105	0.2456	0.2807	0.3158	0.3509	0.3860	0.4211	0.4562	0.4913	0.5264
18	0.0923	0.1231	0.1538	0.1846	0.2154	0.2462	0.2769	0.3077	0.3385	0.3692	0.4000	0.4308	0.4616
20	0.0822	0.1096	0.1370	0.1644	0.1918	0.2192	0.2466	0.2740	0.3014	0.3288	0.3562	0.3836	0.4110
22	0.0741	0.0988	0.1235	0.1481	0.1728	0.1975	0.2222	0.2469	0.2716	0.2963	0.3210	0.3457	0.3704
24	0.0674	0.0899	0.1124	0.1348	0.1573	0.1798	0.2022	0.2247	0.2472	0.2697	0.2922	0.3146	0.3371
26	0.0619	0.0825	0.1031	0.1237	0.1443	0.1649	0.1856	0.2062	0.2268	0.2474	0.2680	0.2887	0.3093
28	0.0571	0.0762	0.0952	0.1143	0.1333	0.1524	0.1714	0.1905	0.2095	0.2286	0.2476	0.2667	0.2857

INSTRUCTIONS:

- Select height (h) of hole in inches and shape of desired hole.
- Calculate Effective Height (EH) of hole in inches using following:
 - Round hole ----- $EH = h$
 - Square hole ----- $EH = h/0.75$
 - Rectangular hole ----- $EH = h/0.6667$
 EH can not be greater than joist depth - 6".
- Find Hole Factor (F) in table above using joist depth and EH. Interpolate F if needed.
- Calculate minimum distance (X) in feet from centerline of bearing to centerline of round hole or edge of square or rectangular hole using following equation:
 $X = F \times \text{Span (Ft.)}$

EXAMPLE:

20" deep joist with 6" x 6" square hole and 25' span.
 Calc EH: $EH = h/0.75 = 6"/0.75 = 8"$
 Find factor F from table: Depth = 20" & EH = 8" F = 0.2192
 Calc X: $X = F \times \text{Span} = 0.2192 \times 25' = 5.48'$ Use X = 5'-6"

NOTES:

- Do not cut the web within nine inches (9") of the bearing centerline, otherwise a two inch (2") round hole can be cut anywhere.
- The top and bottom flanges are never to be cut.
- Where more than one hole is desired, the length of web between edges of hole must be equal or exceed twice the height of the larger hole.
- Factor table is for simple span, uniform loaded joist with shear and/or reaction at maximum allowed.
 If shear or reaction is less than maximum allowed or non-uniform loading is present or there is a cantilever or multiple span, the size and/or location of hole may be effected. Please contact your WEB-i representative to have these conditions checked out.